

# Frequency Distribution Amplifier

Economy Version  
5 to 100 MHz, 1 Input, 16 Outputs

Part No: 10278



## Key features:

- Compact design (1HU), rack mountable
- Low phase noise
- High output-to-output and reverse isolation
- Excellent input and output match to 50  $\Omega$
- Useable from 100 kHz to 200 MHz
- Excellent for high performance frequency references
- AC and DC inputs, automatic switch-over

# Frequency Distribution Amplifier

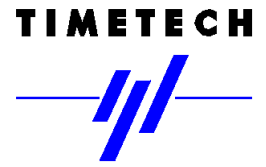

**Part No: 10278**

Economy Version, 5 to 100 MHz, 1 Input, 16 Outputs

The Frequency Distribution Amplifier is a one height unit rack mountable unit. The unit allows a cost and space efficient way to distribute reference frequencies throughout a system without any loss or degradation. The standard product gain is 0 dB. Different gain is available on customer request.

The Distribution Amplifier is optimised for very low phase noise, very good input and output match to 50 Ω and for excellent isolation – this is for output to output and output to input.

The Distribution Amplifier provides high stability of signal delay so that it can be used with high precision frequency source such as caesium clocks.

The Distribution Amplifier is designed to minimise phase noise and shows the following performance, measured under laboratory environment, temperature +18 .. +24°C, controlled to 1K pp with maximum slopes of 0.5 K/h:

Freq. Offset [Hz]	Phase Noise [dBc]		
	5 MHz	10 MHz	100 MHz
0.1 Hz	-132		
1 Hz	-142	-141	-131
10 Hz	-149	-148	-140
100 Hz	-152	-152	-150
1000 Hz	-153	-153	-153
10000 Hz	-153	-153	-153

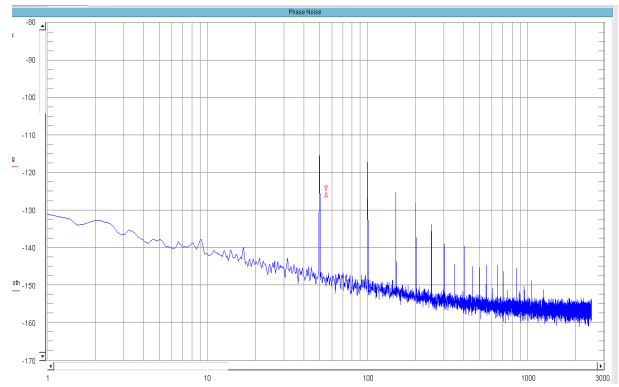

Phase noise at 100 MHz, +8 dBm

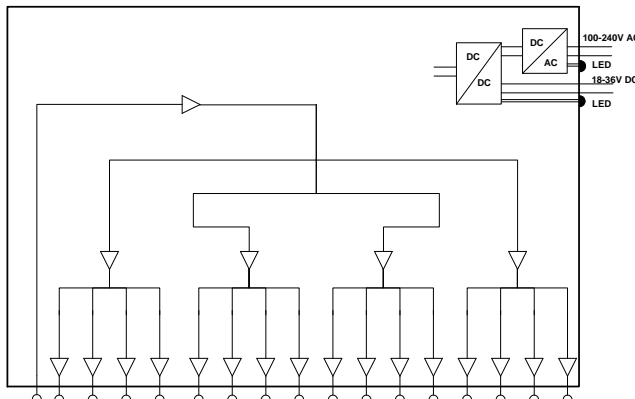

Block diagram of the Frequency Distribution Amplifier

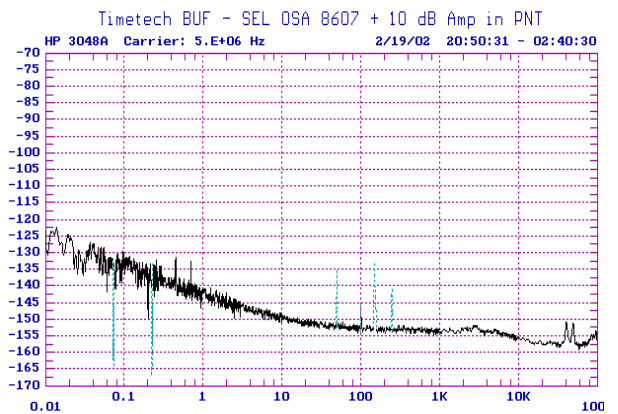

Phase noise at 5 MHz, +13 dBm, 0.01 Hz to 100 kHz

# Frequency Distribution Amplifier

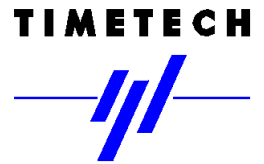

**Part No: 10278**

Economy Version, 5 to 100 MHz, 1 Input, 16 Outputs

## Specification

### Signal Inputs

Number of inputs 1  
Frequency 5 to 100 MHz, sine wave, useable from 100 kHz to 200 MHz  
Input impedance 50  $\Omega$ , nominal  
Input level working +6 to +17 dBm (+14 dBm @ 100 MHz)  
Input level nominal +13 dBm  
Input return loss > 45 dB @ 5MHz and 10 MHz, > 35 dB @ 100 MHz  
Connectors BNC

### Signal Output

Number of outputs 16  
Gain 0 dB (+ 0.15 / -0.1 dB, 1 – 100 MHz, +0.1 to – 0.8 dB @ 200 MHz)  
Gain variation < 0.1 dB, output vs. output  
Output impedance 50  $\Omega$ , nominal  
Output return loss > 45 dB @ 5MHz and 10 MHz, > 35 dB @ 100 MHz  
Connectors BNC  
Noise figure < 22.0 dB, (20 dB typ. 1 – 100 MHz)

Group delay absolute, 1 – 100 MHz 5.0 ns  $\pm$  1 ns  
Group delay flatness, 1 – 100 MHz < 0.1 ns pp  
Group delay variation, channel vs channel < 0.1 ns  
Group delay variation versus temperature < 6 ps / K

	5 MHz	10 MHz	100 MHz
Gain compression: - 0.1 dB at Pout = + 17 dBm	+ 17 dBm	+ 17 dBm	+ 14 dBm
Gain compression: -1 dB at Pout = + 18 dBm	+ 18 dBm	+ 18 dBm	+ 15 dBm
Reverse Isolation [dB]	> 140 (143 typ.)	> 130 (135 typ.)	> 105 (110 typ.)
Output / Output Isolation [dB]	> 100 (108 typ.)	> 90 (100 typ.)	> 70 (80 typ.)
Harmonics [dBc] +10 dBm	-76 -76 -80	-70 -58 -65	-44 -46 -60
(1 <sup>st</sup> , 2 <sup>nd</sup> , 3 <sup>rd</sup> ) +13 dBm	-73 -69 -82	-65 -55 -65	-42 -40 -55

### Electrical interface

Power Consumption AC: < 15 W Priority on AC supply input  
(all outputs loaded) DC: < 10 W, Stand-By: < 0.8 W DC is used as back-up supply  
Supply voltage AC 95 to 265 V AC, 47 to 65 Hz LED indicating AC voltage  
Supply voltage DC 18 to 36 V DC, DC isolated LED indicating DC voltage  
DC connector included, IEC 61076-2-101 M8  
(+) brown (1) & white (2), (-) blue (3) & black (4), polarity reversible

### Mechanical

Outline 19 inch, 1 height unit (448.8 mm \* 44 mm) depth 448 mm  
Weight 1.5 kg

### Environmental

Transportation and Storage  
Temperature. -20°C to +75°C  
Humidity 10% to 90% (non condensing)  
Altitude < 20 000 m  
Shock max 10 g acceleration for 11 ms  
Vibration max. 0.15 mm at 5 to 8 Hz, max 1g acceleration at 8 to 500 Hz  
Operation  
Temperature -10°C to +50°C  
Humidity 20% to 90% (non condensing)  
Altitude < 3 000 m